

8018Gt

Micro Diaphragm Air Pump

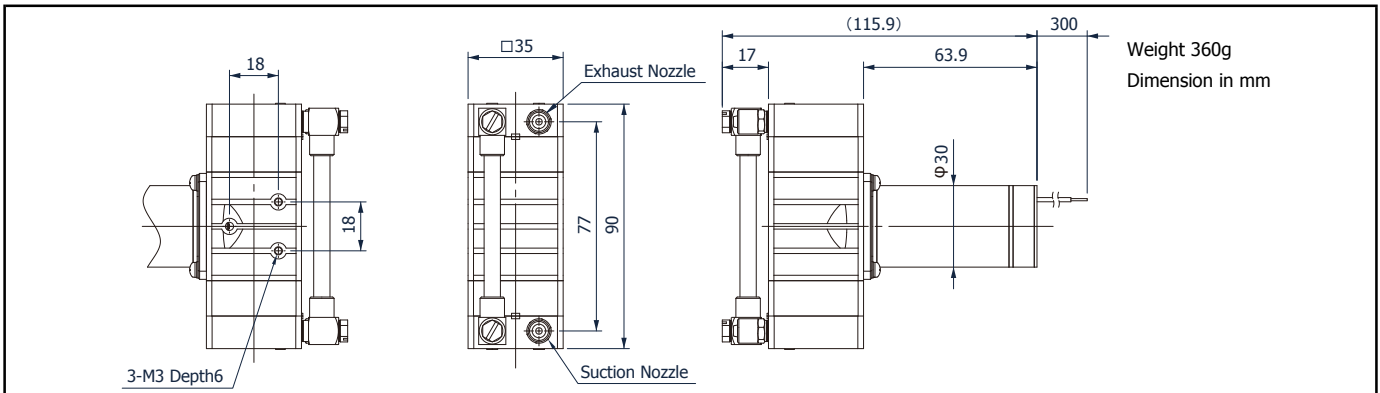

Ordering number

	8018Gt	
Nominal voltage	24	V
Motor type	Namiki DC Brushless	
Drive circuit type	Integrated Sensor	
Maximum flow rate	2,000	ml/min
Nominal current consumption	200	mA
Exhaust pressure range	0...+170	kPa
Suction pressure range	-563...0 (-75...0 kPa)	mm Hg

Performance characteristics

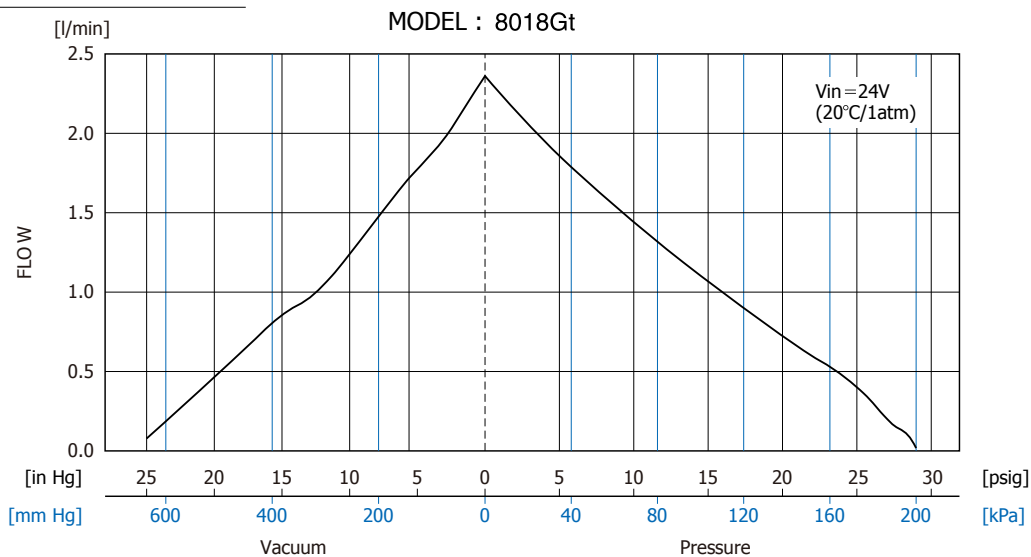

Options:

For special solutions or different wetted materials, please contact our sales division.

General Specifications

Ambient temperature range	+5...+50	°C
Fluid temperature	+5...+50	°C
Rubber material	FKM	
Resin material	POM	

Conditions: Data displayed in this catalog are measured with purified water at 20°C using a Toalon-G tube of 4mm internal (6mm external) diameter and 140cm length using Namiki standard test equipment.