

7038

Micro Diaphragm Liquid Pump

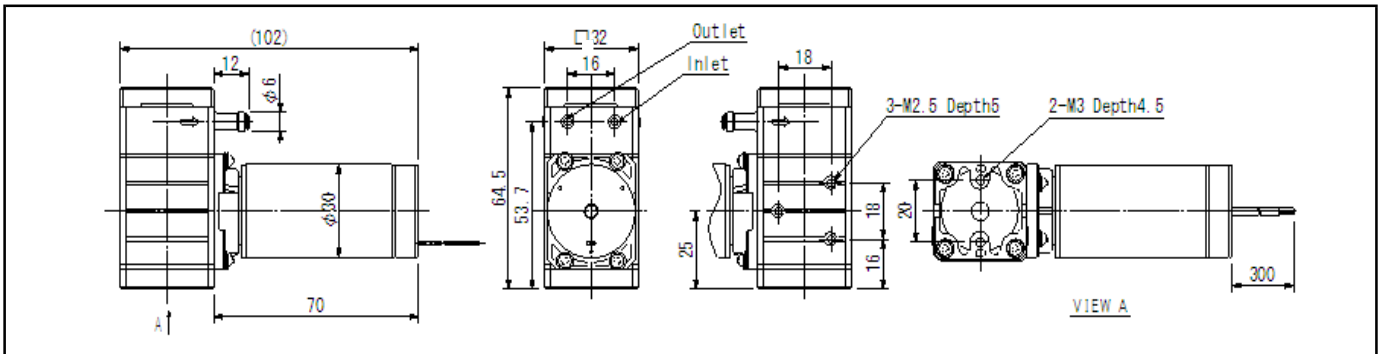

Ordering number

		7038	
Nominal voltage		24	V
Motor type		Namiki DC Brushless	
Drive circuit type		Integrated Sensorless	
Maximum flow rate		630	ml/min
Nominal current consumption		370	mA
Exhaust pressure range		0...+100	kPa
Suction pressure range		-375...0 (- 50...0 kPa)	mm Hg

Performance characteristics

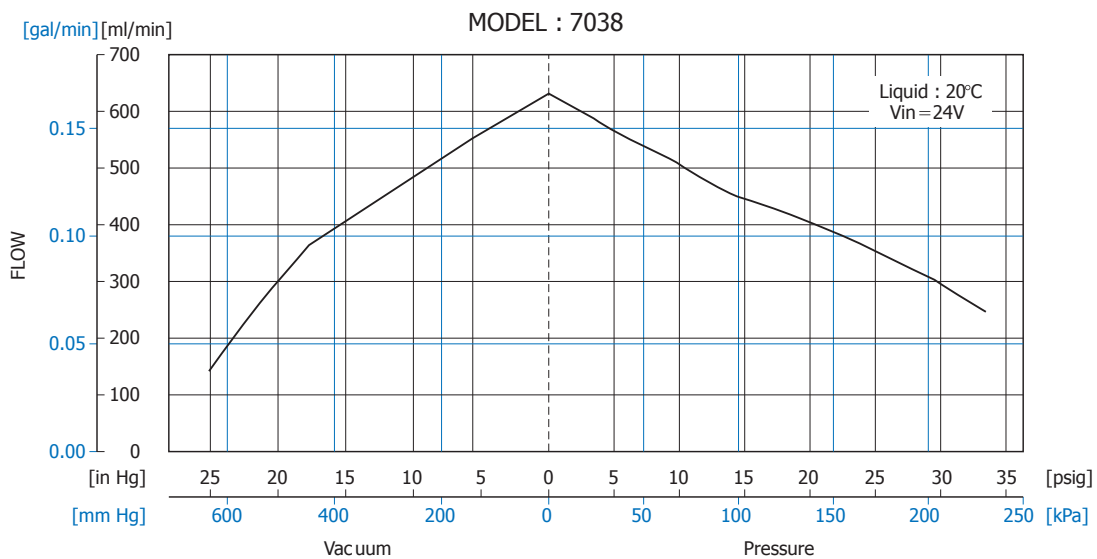

Options:

For special solutions or different wetted materials, please contact our sales division.

Ordering number	7048
Diaphragm	PTFE

General Specifications

Ambient temperature range	+5...+50	°C
Fluid temperature	+5...+50	°C
Rubber material	FKM	
Resin material	PFA, POM	

Conditions: Data displayed in this datasheet are measured with purified water at 20° C using a Toalox-G tube of 4 mm internal (6mm external) diameter and 160cm length using Namiki standard test equipment.