

5013 & 5014

Micro Diaphragm Liquid Pump

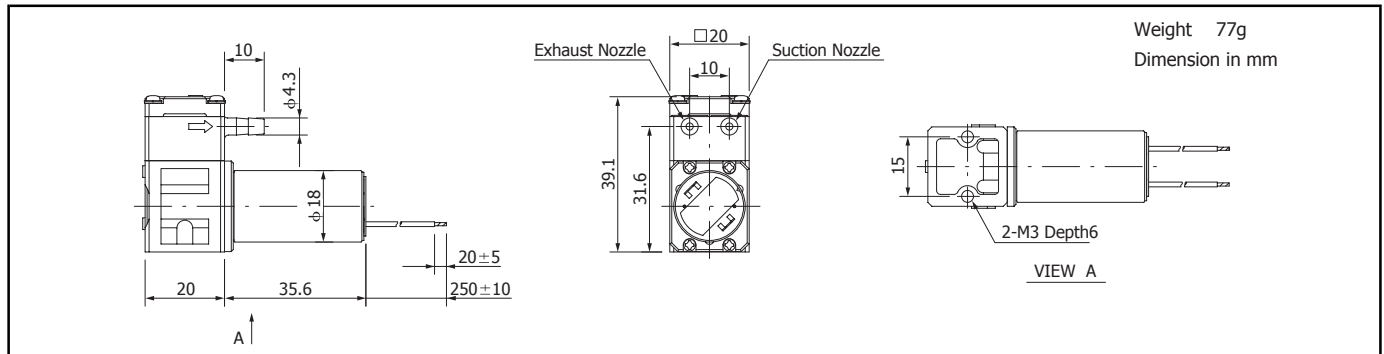

Ordering number

	5013	5014	
Nominal voltage	12	24	V
Motor type	Namiki DC Coreless	Namiki DC Coreless	
Brush type	Graphite	Graphite	
Maximum flow rate	180	190	ml/min
Nominal current consumption	190	110	mA
Exhaust pressure range	0...+70	0...+70	kPa
Suction pressure range	-225...0 (-30...0kPa)	-225...0 (-30...0 kPa)	mm Hg

Performance characteristics

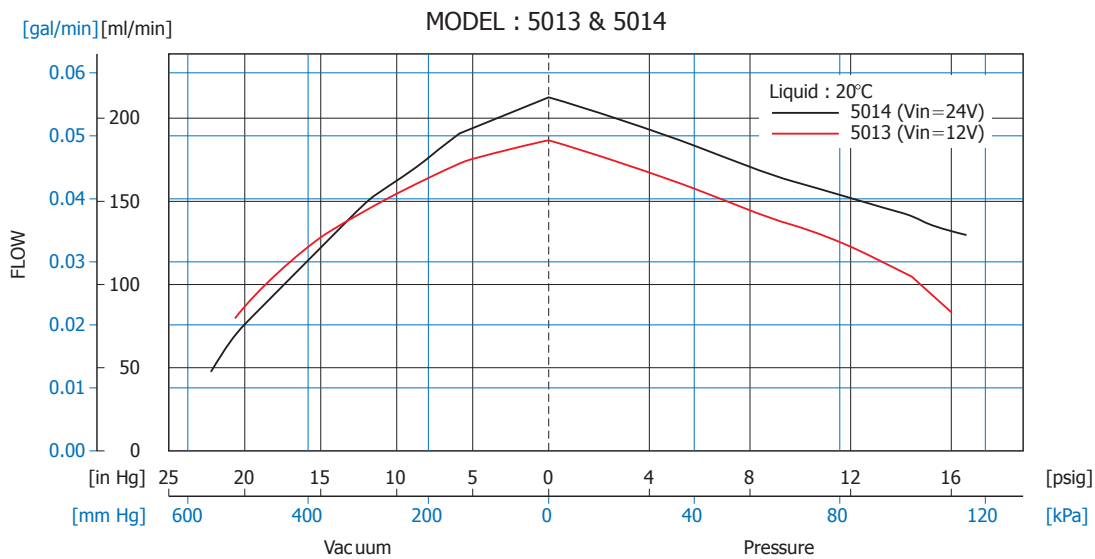

Options:

For special solutions or different wetted materials, please contact our sales division.

Ordering number	5033	5034	5043	5044
Diaphragm	FKM Option	FKM Option	PTFE	PTFE

Nozzle

OD 5mm nozzle is available.

General Specifications

Ambient temperature range	+5...+50	°C
Fluid temperature	+5...+50	°C
Rubber material	FKM	
Resin material	PFA, POM	

Conditions: Data displayed in this datasheet are measured with purified water at 20°C using a Toalon-G tube of 4 mm internal (6mm external) diameter and 160cm length using Namiki standard test equipment.