

SSG12

Spur gearhead

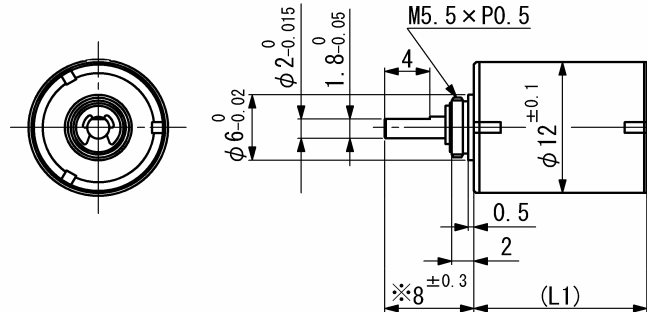

Dimension in mm

Note) Dimension marked ※ is measured with shaft pushed against gearhead.

For combination with motors: SCL12-20, SCL12-22, SCL12-30

General specifications	SSG12	
Housing material	Metal	
Geartrain material	Metal	
Recommended max. input speed	8000	rpm
Operating temperature range	-10...+60	°C
Max. backlash at no-load, 5 stages	≤ 5	°
Bearings on output shaft	Sintered sleeve bearings	
Max. shaft radial load (10 mm from flange)	3	N
Max. shaft axial load	1	N
Max. shaft press fit force	20	N
Shaft radial play	≤ 0.03	mm
Shaft axial play	≤ 0.2	mm

Ratio (nominal)	Stage	Gearhead length, L1 [mm]	Gearhead weight [g]	Max. allowable torque [mNm]		Length with motor [mm]				Efficiency [%]	Direction of rotation	
				Continuous	Intermittent	SCL12-20	SCL12-22	SCL12-30				
16 : 1	3	14	8.3	12	30	35	37	46			73	≠
25 : 1	3	14	8.3	12	30	35	37	46			73	≠
47 : 1	4	16	9.2	15	30	37	39	48			66	=
74 : 1	4	16	9.2	15	30	37	39	48			66	=
94 : 1	4	16	9.2	15	30	37	39	48			66	=
175 : 1	5	18	10.2	15	30	39	41	50			59	≠
282 : 1	5	18	10.2	15	30	39	41	50			59	≠

V01

Namiki Precision of Singapore Pte Ltd.
 TEL: +65-6227-2862 FAX: +65-6227-3327
 URL: www.namikisingapore.com.sg/
 E-mail: namikisales@nps.com.sg

Specifications subject to change without notice