

SCL10-30

Precious metal commutation

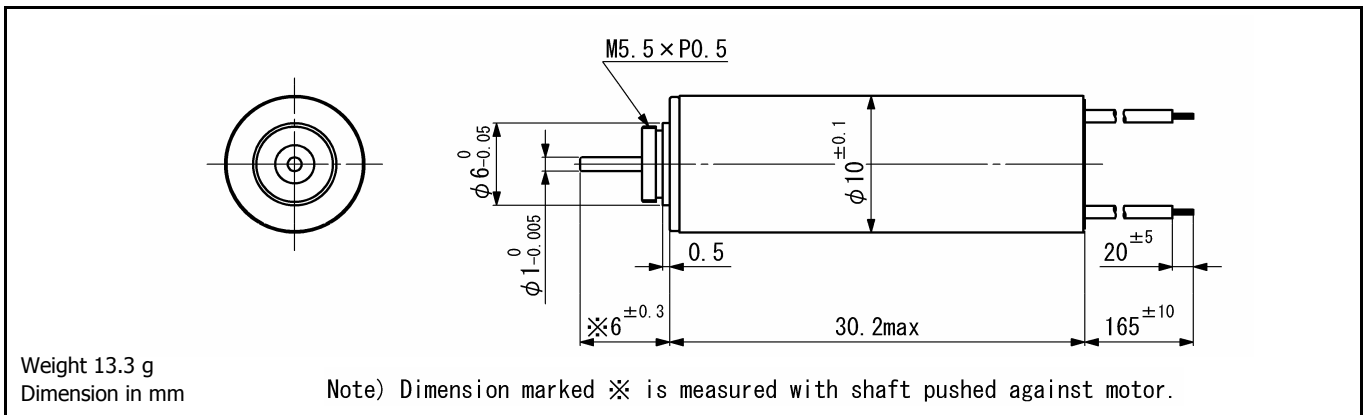

For combination with gearheads: SSG10, SPG10

Ordering number		SCL10-3008	SCL10-3014
1 Nominal voltage		4.5	4.5 V
2 Terminal resistance		7.8	14.3 Ω
3 Output power		0.63	0.34 W
4 Efficiency		73	72 %
5 No-load speed		10160	8800 rpm
6 No-load current		13	7 mA
7 Stall torque		2.35	1.47 mNm
8 Friction torque		0.05	0.03 mNm
9 Back-EMF constant		0.43	0.5 mV/rpm
10 Torque constant		4.14	4.77 mNm/A
11 Slope of N-T curve		4330	6000 rpm/mNm
12 Coil inductance		0.14	0.15 mH
13 Mechanical time constant		7.6	8.4 ms
14 Rotor inertia		0.17	0.13 gcm ²

Continuous operation

15 Speed range		8100	7000 rpm
16 Max. torque		1.17	0.73 mNm

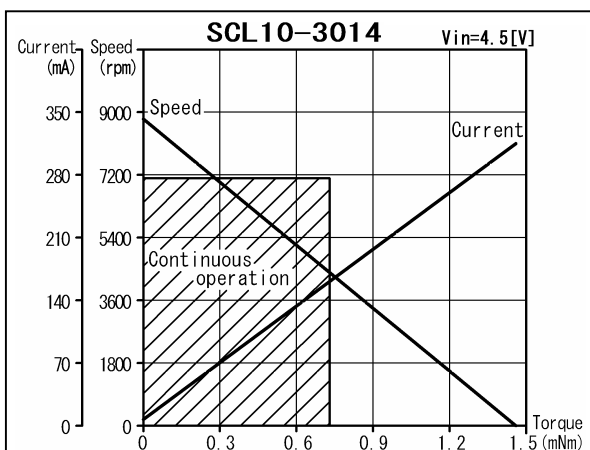

General specifications

17 Operating temperature	-20...+60	°C
18 Max. coil temperature	+80	°C
19 Thermal resistances	$R_{th1} = 11, R_{th2} = 39$	K/W
20 Bearings type	Sintered sleeves	
21 Max. shaft radial load	0.5 (5 mm)	N
22 Max. shaft axial load	0.15	N
23 Max. axial load at standstill	7.8	N
24 Shaft radial play	0.05	mm
25 Shaft axial play	0.03...0.2	mm

Options: Lead wires length, shaft length, special coils, commutator with capacitors.

SPG10

Planetary gearhead

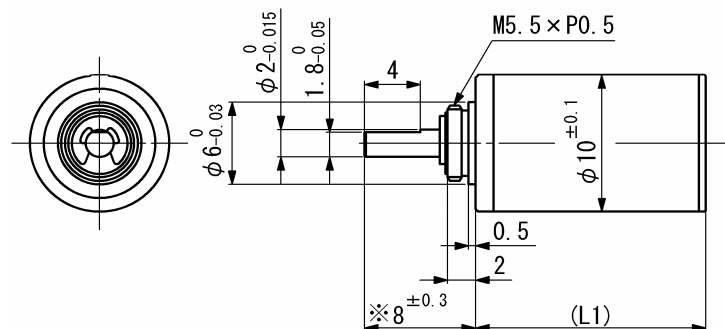

Dimension in mm

Note) Dimension marked ※ is measured with shaft pushed against gearhead.

For combination with motors: SCL10-18, SCL10-30

General specifications

	SPG10	
Housing material	Metal	
Geartrain material	Steel	
Recommended max. input speed	10000	rpm
Operating temperature range	-10...+60	°C
Backlash at no-load per stage	≤ 1	°
Bearings on output shaft	Sintered sleeve bearings	
Max. shaft radial load (6 mm from flange)	3	N
Max. shaft axial load	1	N
Max. shaft press fit force	20	N
Shaft radial play	≤ 0.03	mm
Shaft axial play	≤ 0.3	mm

Ratio (nominal)	Stage	Gearhead length, L1 [mm]	Gearhead weight [g]	Max. allowable torque [mNm]		Length with motor [mm]				Efficiency [%]	Direction of rotation	
				Continuous	Intermittent	SCL10-18	SCL10-30					
3.6 : 1	1	10.5	5.8	50	100	28.6	40.7				85	=
4.7 : 1	1	10.5	5.8	50	100	28.6	40.7				85	=
13 : 1	2	13.5	7.1	50	100	31.6	43.7				72	=
22 : 1	2	13.5	7.1	50	100	31.6	43.7				72	=
61 : 1	3	16.5	8.4	50	100	34.6	46.7				61	=
105 : 1	3	16.5	8.4	50	100	34.6	46.7				61	=
288 : 1	4	19.6	9.7	50	100	37.7	49.8				52	=
494 : 1	4	19.6	9.7	50	100	37.7	49.8				52	=

SSG10

Spur gearhead

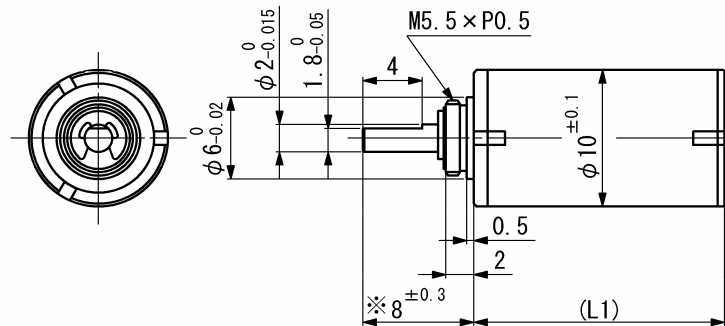

Dimension in mm

Note) Dimension marked ※ is measured with shaft pushed against gearhead.

For combination with motors: SCL10-12, SCL10-18, SCL10-30

General specifications

	SSG10	
Housing material	Metal	
Geartrain material	Metal	
Recommended max. input speed	10000	rpm
Operating temperature range	-10...+60	°C
Max. backlash at no-load with 6 stages	≤ 7	°
Bearings on output shaft	Sintered sleeve bearings	
Max. shaft radial load (6 mm from flange)	3	N
Max. shaft axial load	1	N
Max. shaft press fit force	20	N
Shaft radial play	≤ 0.03	mm
Shaft axial play	≤ 0.2	mm

Ratio (nominal)	Stage	Gearhead length, L1 [mm]	Gearhead weight [g]	Max. allowable torque [mNm]		Length with motor [mm]			Efficiency [%]	Direction of rotation
				Continuous	Intermittent	SCL10-12	SCL10-18	SCL10-30		
15 : 1	3	14	5.4	12	30	27	32.1	44.2	73	≠
29 : 1	4	16	6.2	12	30	29	34.1	46.2	66	=
49 : 1	5	18	7	12	30	31	36.1	48.2	59	≠
72 : 1	5	18	7	12	30	31	36.1	48.2	59	≠
93 : 1	5	18	7	12	30	31	36.1	48.2	59	≠
262 : 1	6	20	7.9	12	30	33	38.1	50.2	53	=