

SBL04-08

Electronically commutated sensorless motor, slotless stator design

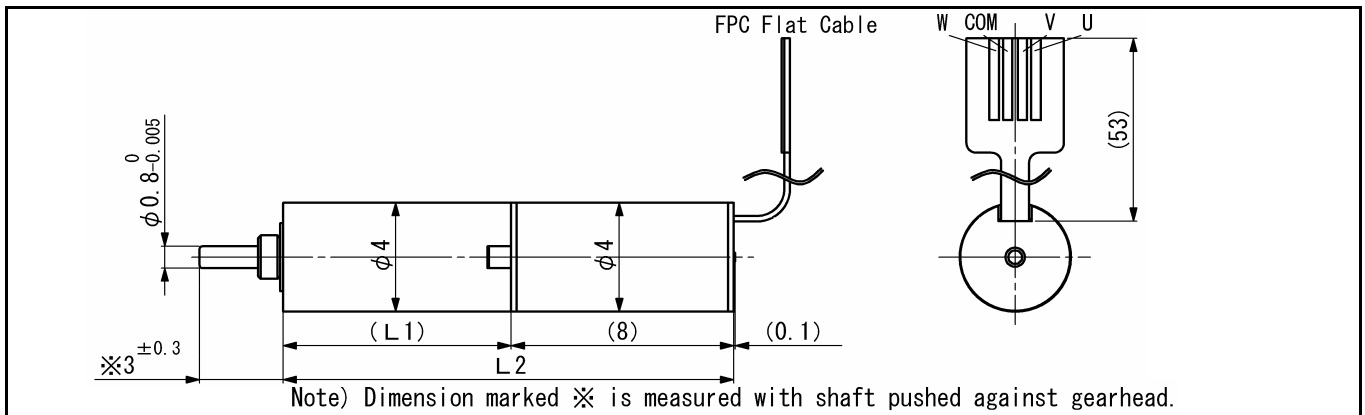

Sensorless drive circuit SSD04

Ordering number	SBL04-0829	SBL04-0829	SBL04-0829	SBL04-0829
	PG04-4.3	PG04-18	PG04-79	PG04-337
1 Nominal voltage	3	3	3	3 V
2 Terminal resistance	29	29	29	29 Ω
3 Gearhead reduction ratio	4.3	18	79	337 :1
4 Gearhead number of stage	1	2	3	4
5 Max. output power, gearhead output	0.02	0.02	0.01	0.01 W
6 Max. efficiency, motor only	12	11	11	9 %
7 No-load speed, gearhead output	7000	1500	350	85 rpm
8 No-load current	44	45	46	50 mA
9 Stall torque (2-points measurement), gearhead output	0.13	0.43	1.5	5.7 mNm
10 Friction torque	0.10	0.35	1.3	5.6 mNm
11 Back-EMF constant	0.24	1.1	4.7	17.8 mV/rpm
12 Torque constant	2.3	7.7	27.3	111.8 mNm/A
13 Coil inductance	74	74	74	74 μH
14 Mechanical time constant, motor only	5	5	5	5 ms
15 Gearhead length, L1	5.8	7	8.2	9.4 mm
16 Total length, L2	13.8	15	16.2	17.4 mm
17 Rotor inertia, motor only	9×10^{-4}	9×10^{-4}	9×10^{-4}	9×10^{-4} gcm ²
18 Total weight	810	990	1010	1030 mg

General data

19 Operating temperature range	-20 ... +70	°C
20 Max. temperature raise at stall	55	°C
21 Bearing type	Sintered sleeves	
22 Max. permissible press fit force, gearhead output	5	N
23 Max. radial play, gearhead output	0.044	mm
24 Max. axial play, gearhead output	0.15	mm

Ordering example

SBL04-0829PG18 corresponds to:
 Motor SBL04-0829 +
 Planetary gearhead SPG04-18

SSD04

Sensorless brushless motor drive circuit

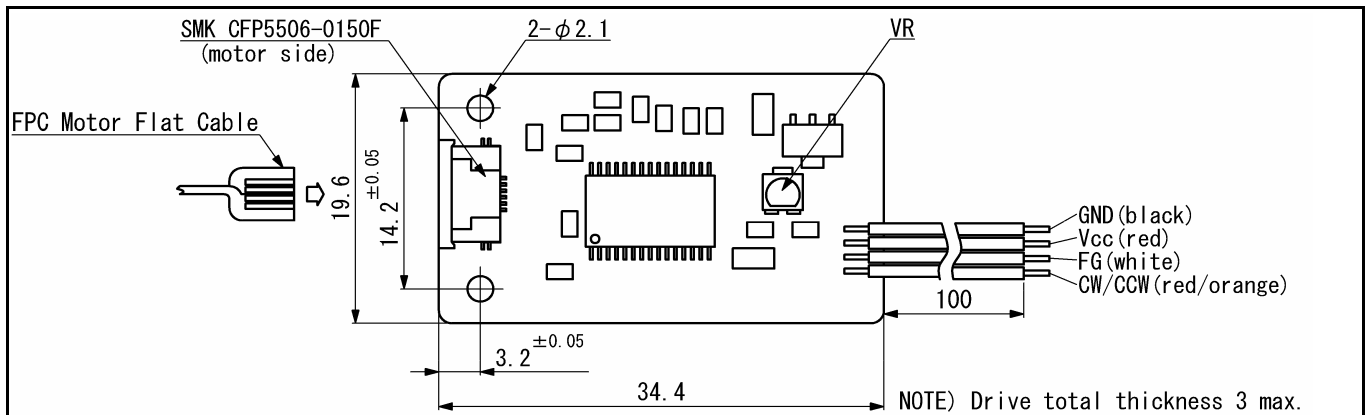

For Micro DC brushless motors **SBL02-06** and **SBL04-08**

Description

SSD04 is a 3-phase sensorless drive circuit designed to operate brushless motor SBL02-06 and SBL04-08 exclusively. The operating voltage can be adjusted by VR trimmer and motor shaft direction can be reversed by connecting CW/CCW input to Vcc, if not connected the SBL02-06 runs CW while SBL04-08 CCW. FG (Frequency Generator) output provides a pulse per motor revolution. Internal thermal protection circuit included.

Specifications

	SSD04			
	Min.	Typ.	Max.	
Voltage supply	2.7		6.0	V
Output voltage			4.9	V
Output current			0.8	A
Operating temperature range	-20 ... +75			°C
Weight	1.9			g